

Saddle Stitching Layout Guidelines

Good binding lap planning will keep your costs low and your life easy. Here are some saddle stitching layout guidelines:

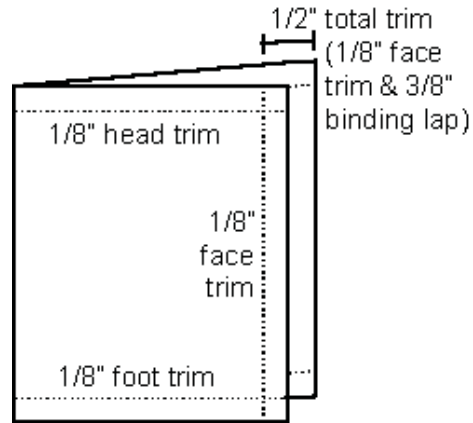

- Allow a minimum of 1/8" trim for the head, foot and face of the signature.
- BRCs can be jogged to the head or foot and appropriately trimmed, or placed in the center to avoid trimming.
- If you have crossover registration concerns, use parallel folding sequences on 8-, 12- and 16-page signatures. For best quality, avoid right angle folding sequence layouts.

Sample Layout: 16-Page Parallel Form

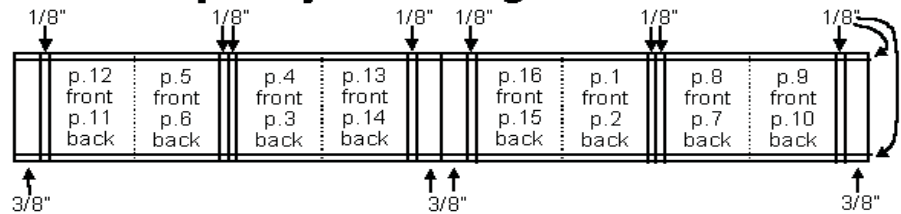

When in doubt, ask your bindery expert for layout advice ... early!

If you have questions, call us at 781-932-3908.

To submit an estimate, either click on the provided link or fax it to 781-932-3803.



The Seaboard Advantage

At Seaboard Bindery, we have the knowledge, experience and production capabilities to help you turn great ideas into attractive pieces. Even the "simple" projects need advance planning to turn out properly. Involve us early in your project to be sure the final product meets both your demands and those of your clients.

Services offered:

- Perfect Binding
- Mechanical Binding
- Saddle Stitching
- Die Cutting
- Folding
- Film Laminating
- Index Tabbing
- Design & Planning
- And More!